

Disassembly Instructions, EasyPac, Offset, 1 x Compactor

Rev. Date: 2016-11-10 – SPID: 1756/0.4 (-) – Disassembly Instructions, EasyPac, Offset, 1 x Compactor – Basic 90137004-Tomra EasyPac Unit Offset 1xComp

Notice	<ul style="list-style-type: none"> • There are variants of this module, causing minor individual weight variations. • Parts containing plastic, steel and cables should be separated. Printed circuit boards should be separated from steel. 	
---------------	----------------------------------------------------------------------------------------------------------------------------------------------------------------------------------------------------------------------------------------------------------------------	-------------------------------------------------------------------------------------

Suggested tools	<ul style="list-style-type: none"> • Socket wrenches 7, 8, 10 and 30 mm • Wrenches 10, 24 and 30 mm • Torx screwdriver T20 • Hex keys 2.5 and 4 mm • Side cutting pliers, medium • Power drill with 5mm drill bit
------------------------	-------------------------------------------------------------------------------------------------------------------------------------------------------------------------------------------------------------------------------------------------------------------------------

Part number	90137004	Name	Tomra EasyPac Unit Offset 1xComp
--------------------	----------	-------------	----------------------------------

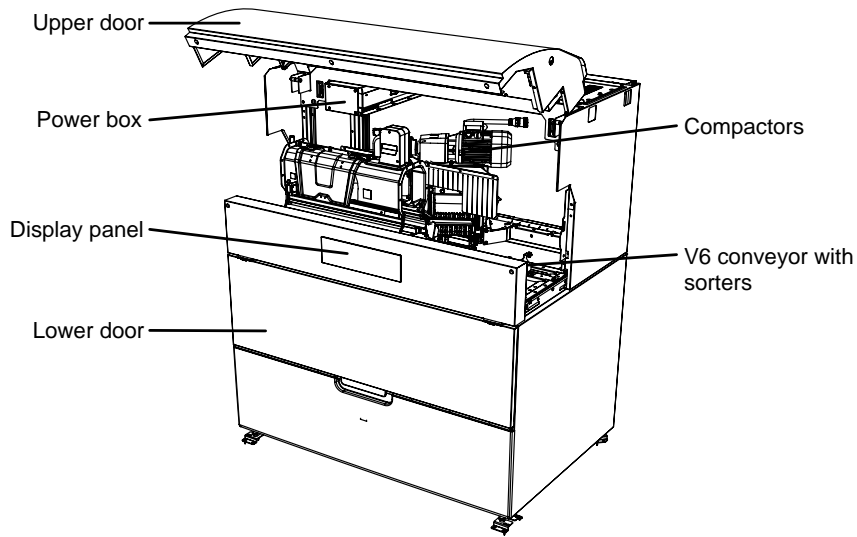

Material type and weight (approximate)	Steel and Iron	140 kg	Plastics	2 kg	Cables	2 kg
	Aluminum	1 kg	Rubber	–	Other	kg
	EEE parts	10.5 kg	Zink	2.2 kg	Other	kg

Dismantling procedure (ref service manual)

Suggested dismantling procedure		
Step	Part	Material
1	Upper door	Steel, Iron
2	Lower door	Steel, Iron, Plastic
3	V6 conveyor with sorter	Steel, Iron, Plastic, Cable (EEE), Motor
4	Power box	EEE part, Plastic, PCB
5	Compactor	Steel, Motor, Cable (EEE)
6	Cables, photocells, switches	Cable (EEE)